

# TNHFCMP-RCV Optical Receiver Manual

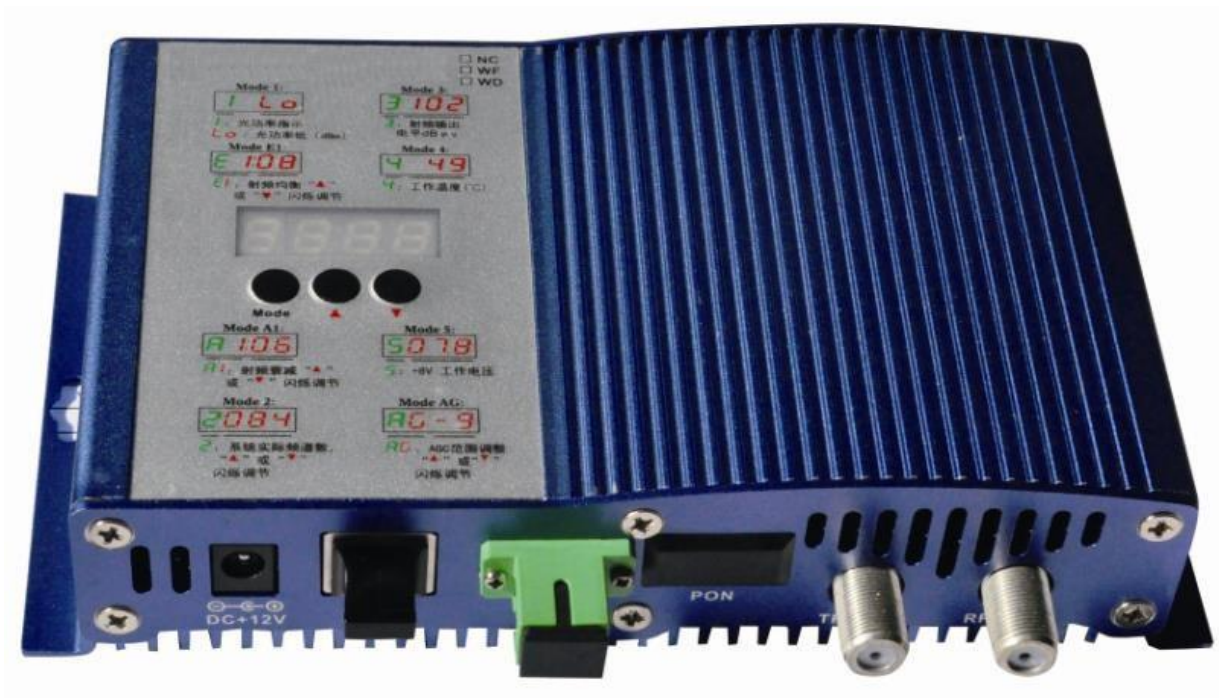

## 1. Product Summary

TNHFCMP-RCV optical receiver is our latest 1GHz FTTB optical receiver. With wide range receiving optical power, high output level and low power consumption. It is an ideal equipment to build the high-performance NGB network.

There are three models for option:

**TNHFCMP-RCV-NC:** The RFTV operating wavelength is 1100 ~ 1620nm.

**TNHFCMP-RCV-WF:** Built-in optical signal filter, the RFTV operating wavelength is 1550nm.

**TNHFCMP-RCV-WD:** Built-in CWDM, RFTV operating wavelength is 1550nm. Pass 1310/1490nm wavelength. Can be connected with EPON, GPON and ONU.

## 2. Performance Characteristics

- Adopt advanced optical AGC control technique, the maximum AGC control range (adjustable) is  $-9 \sim +2$ dBm;
- RF amplifier part adopts the high-performance low power consumption GaAs chip, the highest output level up to 112dB $\mu$ V;
- EQ and ATT both use the professional electric control circuit, make the control more accurate, operation more convenient;
- Built-in Ethernet transponder, support remote network management (optional);
- Compact structure, convenient installation, is the first-choice equipment of FTTB CATV network;
- External high reliability low power consumption power supply;

## 3. Technique Parameter

Item	Unit	Technical Parameters	
<b>Optical Parameters</b>			
Receiving Optical Power	dBm	-9 ~ +2	
Optical Return Loss	dB	>45	
Optical Receiving Wavelength	nm	1100 ~ 1600 or 1530 ~ 1620	
Optical Connector Type		SC/APC	
Fiber Type		Single mode	
<b>Link Parameters</b>			
C/N	dB	$\geq 51$	Note 1
C/CTB	dB	$\geq 60$	
C/CSO	dB	$\geq 60$	
<b>RF Parameters</b>			
Frequency Range	MHz	45 ~862/1003	
Flatness in Band	dB	$\pm 0.75$	
Rated Output Level	dB $\mu$ V	108 (FZ110)	104 (FP204)
Max Output Level	dB $\mu$ V	112 (-7 ~ +2 tap)	108 (-7 ~ +2 two-way splitter)

Output Return Loss	dB	$\geq 16$
Output Impedance	$\Omega$	75
Electrical control EQ range	dB	0~15
Electrical control ATT range	dB	0~15
<b>General Characteristics</b>		
Power Voltage	V	DC12V/1A
Operating Temperature	$^{\circ}\text{C}$	-40~60
Consumption	VA	$\leq 8.5$
Dimension	mm	178 (L) * 115 (W) * 40 (H)

Note 1: Configure 59 PAL-D analog channel signals in the 550MHz frequency range. Transmit digital signal in the frequency range of 550~862/1003MHz. The digital signal level (in 8 MHz bandwidth) is 10dB lower than analog signal carrier level. When the optical input power of the optical receiver is -1dBm, the output level: 108dB $\mu$ V, EQ: 8dB.

## 4. Block Diagram

### TNHFCMP-RCV-NC block diagram

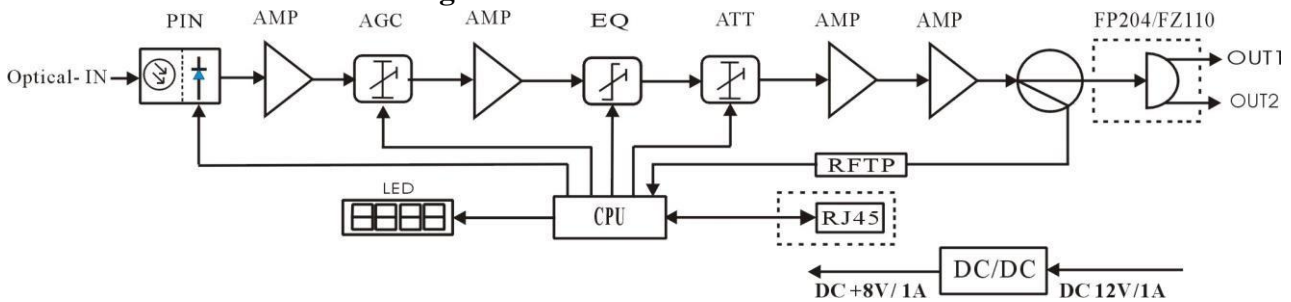

### TNHFCMP-RCV-WF block diagram

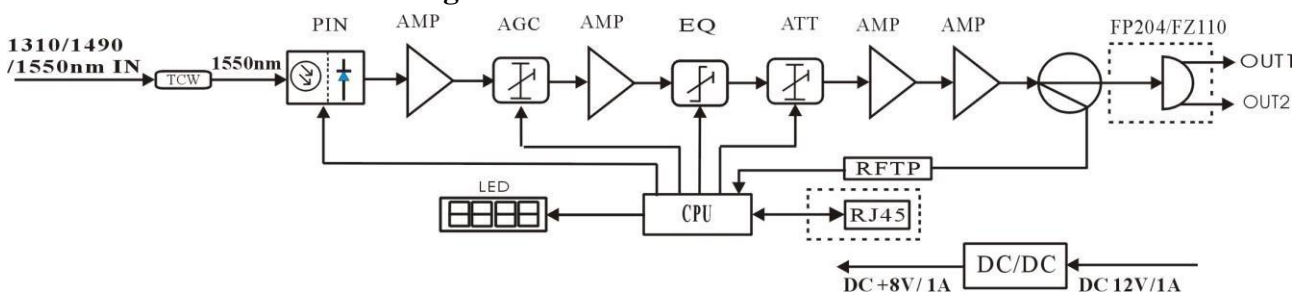

### TNHFCMP-RCV-WD block diagram

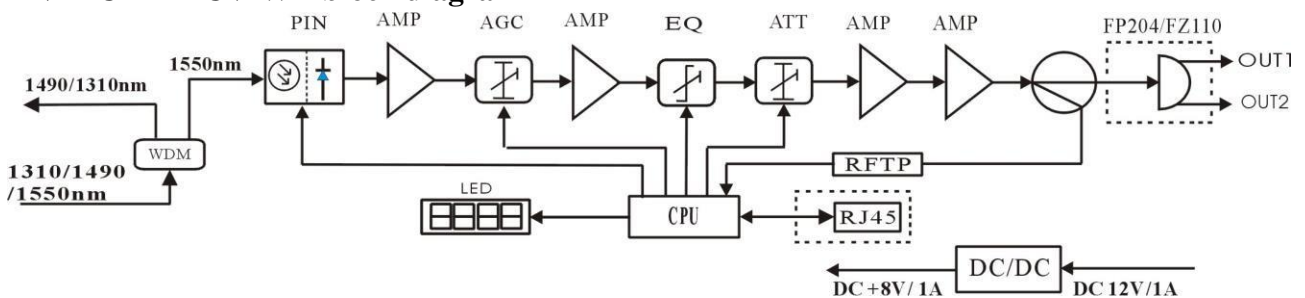

Note: The circuit in the dashed box is optional configuration circuit.



## 5. Relation Table of Optical Input Power and CNR

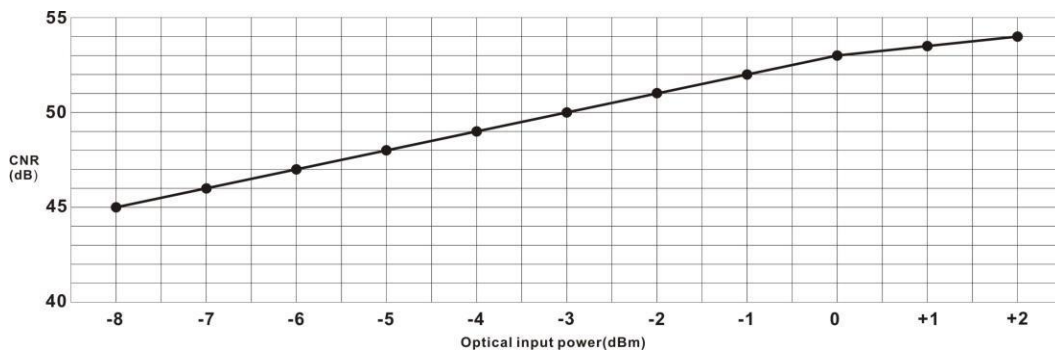

















## 6. Structure Specification

No.	Name	No.	Name
1	Status display digital tube	6	RJ45 network management interface
2	Control mode selection button	7	Optical signal input
3	Parameter adjustment button: Up	8	Optical signal output
4	Parameter adjustment button: Down	9	RF output 1
5	DC12V power input	10	RF output 2

## 7. Function Display and Operating Instruction

Mode: Mode selection button, total eight modes. Press the mode selection button to enter the corresponding status display, eight modes to cycle.

The following is the detailed instructions:

- Mode 1:**  Input optical power (unit dBm)  
: Means that the optical power is low or none  
: Means that the displayed data is the input optical power
- Mode E1:**  RF equilibrium, press “▲” or “▼” button for a few seconds until the data flicker. Then adjust and press “Mode” to confirm. The maximum adjustment range is 15dB.  
: EQ mode, means that the controlled and displayed data is the RF channel equilibrium.
- Mode A1:**  RF attenuation, press “▲” or “▼” button for a few seconds until the data flicker. Then adjust and press “Mode” to confirm. The maximum adjustment range is 15dB.  
: ATT mode, means that the controlled and displayed data is the RF channel attenuation.
- Mode 2:**  The actual number of channels enters into the current network system. Press “▲” or “▼” button for a few seconds until the data flicker. Then adjust and press “Mode” to confirm. The maximum number is 200.  
: The menu is used to display the actual number of channels enters into the current network system, in order to calculate the RF output level more accurately.
- Mode 3:**  RF output level (unit dBuV)  
: Means that the displayed data is the RF output level under the current system.
- Mode 4:**  Working temperature (unit°C)  
: Means that the displayed data is the internal actual ambient temperature.
- Mode 5:**  The actual value of +8V working voltage  
: Means that the displayed data is the actual voltage of +8V
- Mode AG:**  AGC adjustment range (adjustment range -7~-9dBm)  
 Press “▲” or “▼” button for a few seconds until the data flicker. Then adjust and press “Mode” to confirm.  
: Means that the AGC range under the current system is +2~-9dBm  
 If the displayed data is -7, means that the AGC range is +2~-7dBm  
 If the displayed data is -8, means that the AGC range is +2~-8dBm

Note: AGC range per reduce 1dBm, the RF output is raised by 2 dB

## 8. Common Failure Analysis and Troubleshooting

Failure phenomenon	Failure cause	Solution
After connecting the network, the image of the optical contact point has obvious netlike curve or large particles highlights but the image background is clean.	<ol style="list-style-type: none"> <li>The input optical power of the optical receiver is too high, make the output level of the optical receiver module too high and RF signal index deteriorate.</li> <li>The RF signal (input the optical transmitter) index is poor.</li> </ol>	<ol style="list-style-type: none"> <li>Check the input optical power and make appropriate adjustments to make it in the specified range; or adjust the attenuation of optical receiver to reduce the output level and improve index.</li> <li>Check the front end machine room optical transmitter RF signal index and make appropriate adjustments.</li> </ol>
After connecting the network, the image of the optical contact point has obvious noises.	<ol style="list-style-type: none"> <li>The input optical power of the optical receiver is not high enough, results in the decrease of C/N.</li> <li>The optical fiber active connector or adapter of the optical receiver has been polluted.</li> <li>The RF signal level input the optical transmitter is too low, make modulation degree of the laser is not enough.</li> <li>The C/N index of system link signal is too low.</li> </ol>	<ol style="list-style-type: none"> <li>Check the received optical power of the optical contact point and make appropriate adjustments to make it in the specified range.</li> <li>Recover the received optical power of the optical contact point by cleaning the optical fiber connector or adapter etc methods. Specific operation methods see “Clean and maintenance method of the optical fiber active connector”.</li> <li>Check the RF signal level input the optical transmitter and adjust to the required input range. (When the input channels number less than 15, should higher than nominal value.)</li> <li>Use a spectrum analyzer to check the system link C/N and make appropriate adjustments. Make sure the system link signal <math>C/N &gt; 51\text{dB}</math>.</li> </ol>
After connecting the network, the images of several optical contact points randomly appear obvious noises or bright traces.	The optical contact point has open circuit signal interference or strong interference signal intrusion.	<ol style="list-style-type: none"> <li>Check if there is strong interference signal source; change the optical contact point location if possible to avoid the influence of strong interference signal source.</li> <li>Check the cable lines of the optical contact point, if there is shielding net or situation that the RF connector shielding effect is not good.</li> <li>Tightly closed the equipment enclosure to ensure the shielding effect; if possible add shielding cover to the optical contact point and reliable grounding.</li> </ol>
After connecting the network, the images of several optical contact points appear one or two horizontal bright traces.	Power supply AC ripple interference because of the bad earth of equipment or power supply.	Check grounding situation of the equipment, make sure that every equipment in the line has been reliably grounding and the grounding resistance must be $< 4\Omega$ .

<p>After connecting the network, the received optical power of the optical contact point is unstable and has large continuous change. The output RF signal is unstable, too. But the detected output optical power of the optical transmitter is normal.</p>	<p>The optical fiber active connector types do not match, maybe the APC type connect to PC type, make the optical signal cannot normal transmission.</p> <p>The optical fiber active connector or adapter may be polluted seriously or the adapter has been damaged.</p>	<ol style="list-style-type: none"> <li>1. Check the type of optical fiber active connector and adopt the APC type optical fiber active connector to ensure the normal transmission of optical signal.</li> <li>2. Clean the polluted optical fiber active connector or adapter. Specific operation methods see “Clean and maintenance method of the optical fiber active connector”.</li> <li>3. Replace the damaged adapter.</li> </ol>
--	--	--

## 9. Clean and maintenance method of the optical fiber active connector

In many times, we consider the decline of the optical power as the equipment faults, but actually it may be caused by that the optical fiber connector was polluted by dust or dirt. Inspect the fiber connector, component, or bulkhead with a fiberscope. If the connector is dirty, clean it with a cleaning technique following these steps:

1. Turn off the device power supply and carefully pull off the optical fiber connector from the adapter.
2. Wash carefully with good quality lens wiping paper and medical absorbent alcohol cotton. If use the medical absorbent alcohol cotton, still need to wait 1~2 minutes after wash, let the connector surface dry in the air.
3. Cleaned optical connector should be connected to optical power meter to measure output optical power to affirm whether it has been cleaned up.
4. When connect the cleaned optical connector back to adapter, should notice to make force appropriate to avoid china tube in the adapter crack.
5. The optical fiber connector should be cleaned in pairs. If optical power is on the low side after clean, the adapter may be polluted, clean it. (Note: Adapter should be carefully operated, so as to avoid hurting inside fiber.
6. Use compressed air or degrease alcohol cotton to wash the adapter carefully. When use compressed air, the muzzle aims at china tube of the adapter, clean the china tube with compressed air. When use degrease alcohol cotton, insert directions need be consistent, otherwise can't reach a good clean effect.